

CONFIDENTIAL

THIS DOCUMENT AND INFORMATION CONTAINED HEREIN IS PROPRIETARY AND CONFIDENTIAL TO PRECOR STRENGTH INCORPORATED. RECIPIENTS OF THIS DOCUMENT AGREE THAT THIS DOCUMENT AND INFORMATION WILL NOT BE USED FOR ANY PURPOSE, REPRODUCED OR COPIED, OR DISCLOSED TO ANY THIRD PARTY, EITHER IN WHOLE OR IN PART WITHOUT PRIOR EXPRESS WRITTEN PERMISSION OF PRECOR STRENGTH, INCORPORATED.

PRECOR USA
PRECOR STRENGTH, INC.

28936 AVE WILLIAMS
VALENCIA, CA 91355
TELEPHONE: 661-362-0300

SIGN IN BLUE OR BLACK INK ONLY		
DRWN BY	01.02.07	MGP
DWG CHK		
ENG	01.02.07	RSG
MPG ENG		
CS		
QA		
ID		
REG		

UNLESS OTHERWISE SPECIFIED:
DIMENSIONS ARE IN INCHES
TOLERANCES ARE:
LIN .X=±0.1 .XXX=±0.010
LIN .XX=±0.02 .XXXX=±0.0001
ANGULAR: ±1.0°
ALL DIMS AFTER PLATING
BREAK ALL SHARP EDGES
REMOVE ALL BURRS
ALL ANGLES & BENDS 90°
DWG PER ASME Y14.5M-1994
DO NOT SCALE DRAWING
ALL MACHINED SURFACES

PRODUCT:		STRENGTH
ASSEMBLY CONNECTION, 10.5, W/ 1 PULLEY HSG		
DWG. NO.	CW31868-402	SUBREV
		A

SIZE	PAGE	OF
C	1	1

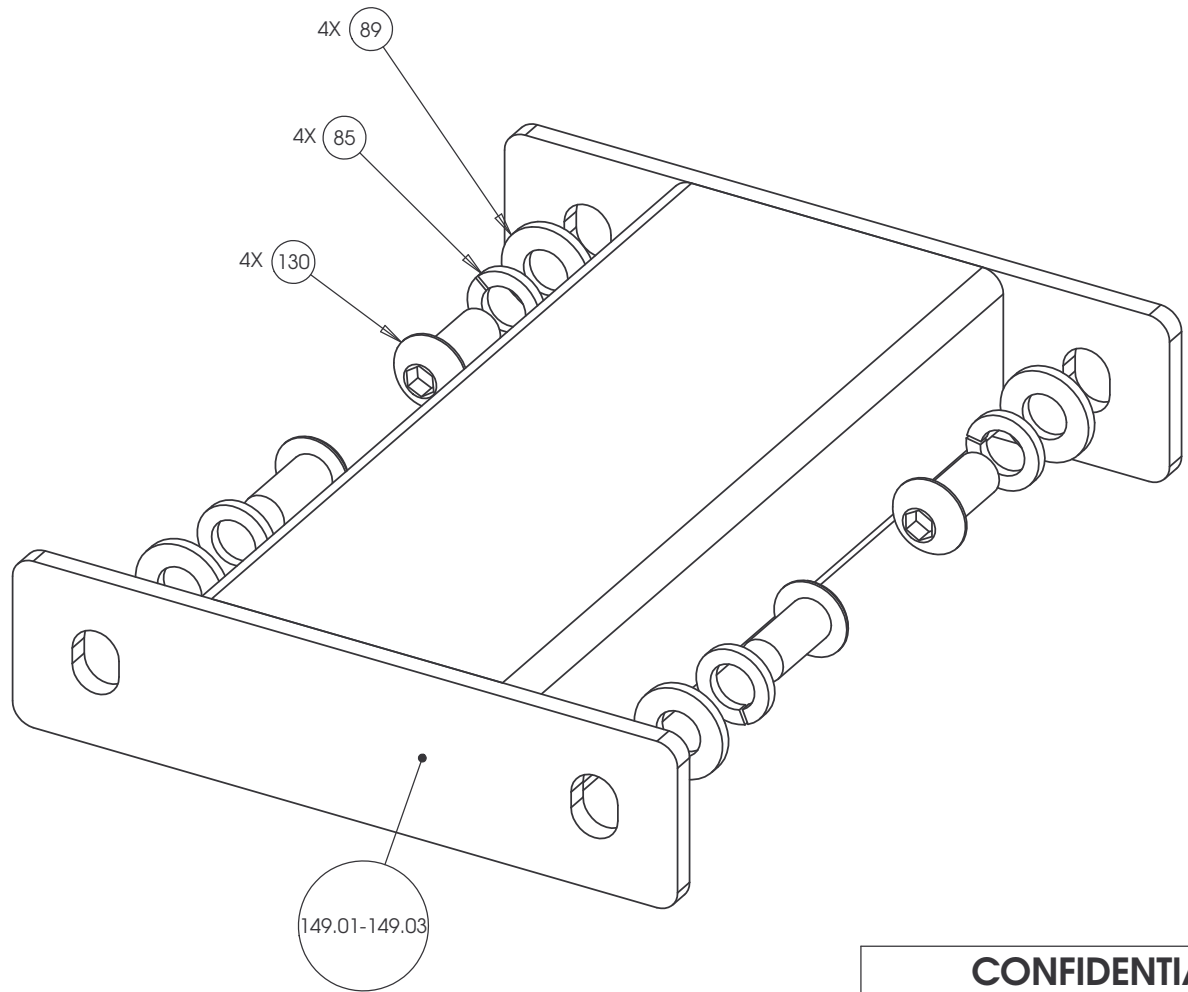

CONFIDENTIAL

THIS DOCUMENT AND INFORMATION CONTAINED HEREIN IS PROPRIETARY AND CONFIDENTIAL TO PRECOR STRENGTH INCORPORATED. RECIPIENTS OF THIS DOCUMENT AGREE THAT THIS DOCUMENT AND INFORMATION WILL NOT BE USED FOR ANY PURPOSE, REPRODUCED OR COPIED, OR DISCLOSED TO ANY THIRD PARTY, EITHER IN WHOLE OR IN PART WITHOUT PRIOR EXPRESS WRITTEN PERMISSION OF PRECOR STRENGTH, INCORPORATED.

PRECOR USA
PRECOR STRENGTH, INC.

28936 AVE WILLIAMS
VALENCIA, CA 91355
TELEPHONE: 661-362-0300

SIGN IN BLUE OR BLACK INK ONLY			UNLESS OTHERWISE SPECIFIED: DIMENSIONS ARE IN INCHES		PRODUCT: STRENGTH
DRWN BY	08.15.06	VLE	TOLERANCES ARE: LIN .X=±0.1 .XXX=±0.010 LIN .XX=±0.02 .XXXX=±0.0001 ANGULAR: ±1.0°		
DWG CHK			ALL DIMS AFTER PLATING BREAK ALL SHARP EDGES REMOVE ALL BURRS ALL ANGLES & BENDS 90° DWG PER ASME Y14.5M-1994 DO NOT SCALE DRAWING ALL MACHINED SURFACES		ASSEMBLY CONNECTION, 10.5
ENG	06.19.06	RSG			
MFG ENG					DWG. NO. CW31874-402
CS					
QA					SUBREV A
ID			SIZE	PAGE OF	
REG			C	1 1	

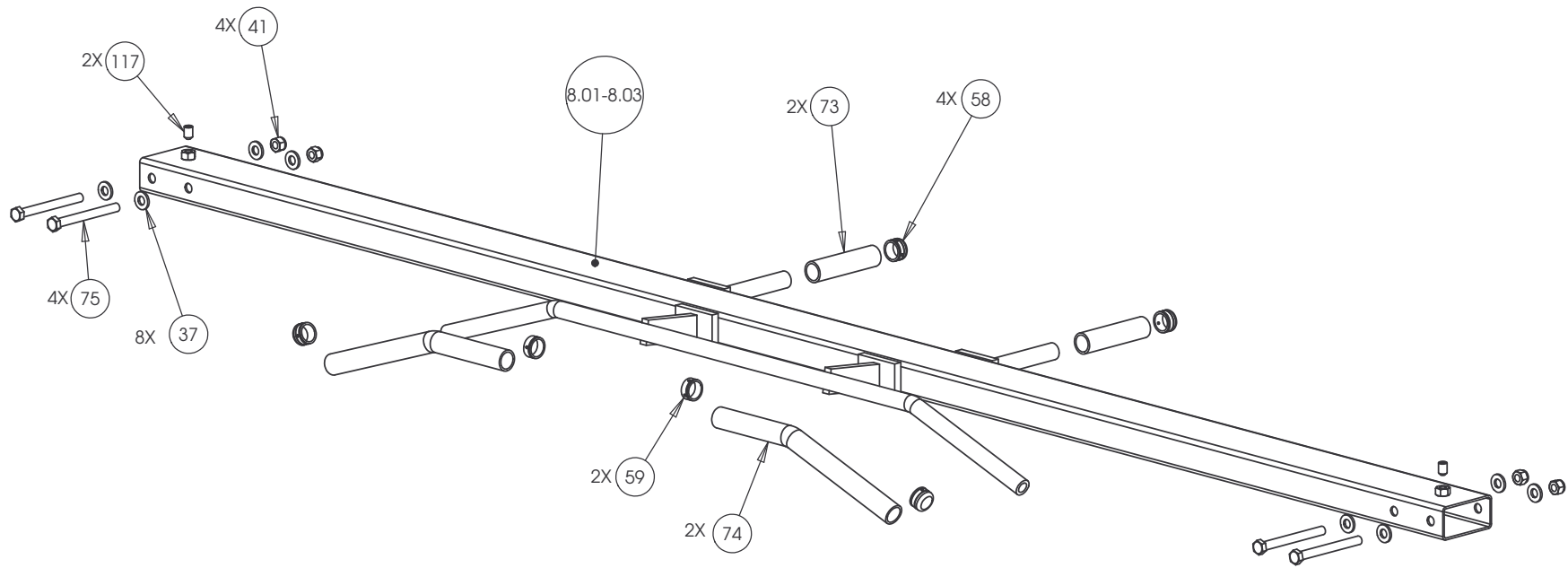

CONFIDENTIAL

THIS DOCUMENT AND INFORMATION CONTAINED HEREIN IS PROPRIETARY AND CONFIDENTIAL TO PRECOR STRENGTH INCORPORATED. RECIPIENTS OF THIS DOCUMENT AGREE THAT THIS DOCUMENT AND INFORMATION WILL NOT BE USED FOR ANY PURPOSE, REPRODUCED OR COPIED, OR DISCLOSED TO ANY THIRD PARTY, EITHER IN WHOLE OR IN PART WITHOUT PRIOR EXPRESS WRITTEN PERMISSION OF PRECOR STRENGTH, INCORPORATED.

PRECOR USA
PRECOR STRENGTH, INC.

28936 AVE WILLIAMS
VALENCIA, CA 91355
TELEPHONE: 661-362-0300

SIGN IN BLUE OR BLACK INK ONLY			UNLESS OTHERWISE SPECIFIED: DIMENSIONS ARE IN INCHES		PRODUCT: STRENGTH
DRWN BY	01.02.07	MGP	TOLERANCES ARE: LIN .X=±0.1 .XXX=±0.010 LIN .XX=±0.02 .XXXX=±0.0001		
DWG CHK			ANGULAR: ±1.0°		ASSEMBLY CONNECTION, 107 IN, CROSSBEAM W-HANDLES
ENG	01.02.07	RSG	ALL DIMS AFTER PLATING BREAK ALL SHARP EDGES REMOVE ALL BURRS		
MFG ENG			ALL ANGLES & BENDS 90°		
CS			DWG PER ASME Y14.5M-1994		
QA			DO NOT SCALE DRAWING		
ID			ALL MACHINED SURFACES		
REG			SIZE	PAGE OF	DWG. NO.
			C	1 1	CW31878-401
					SUBREV A

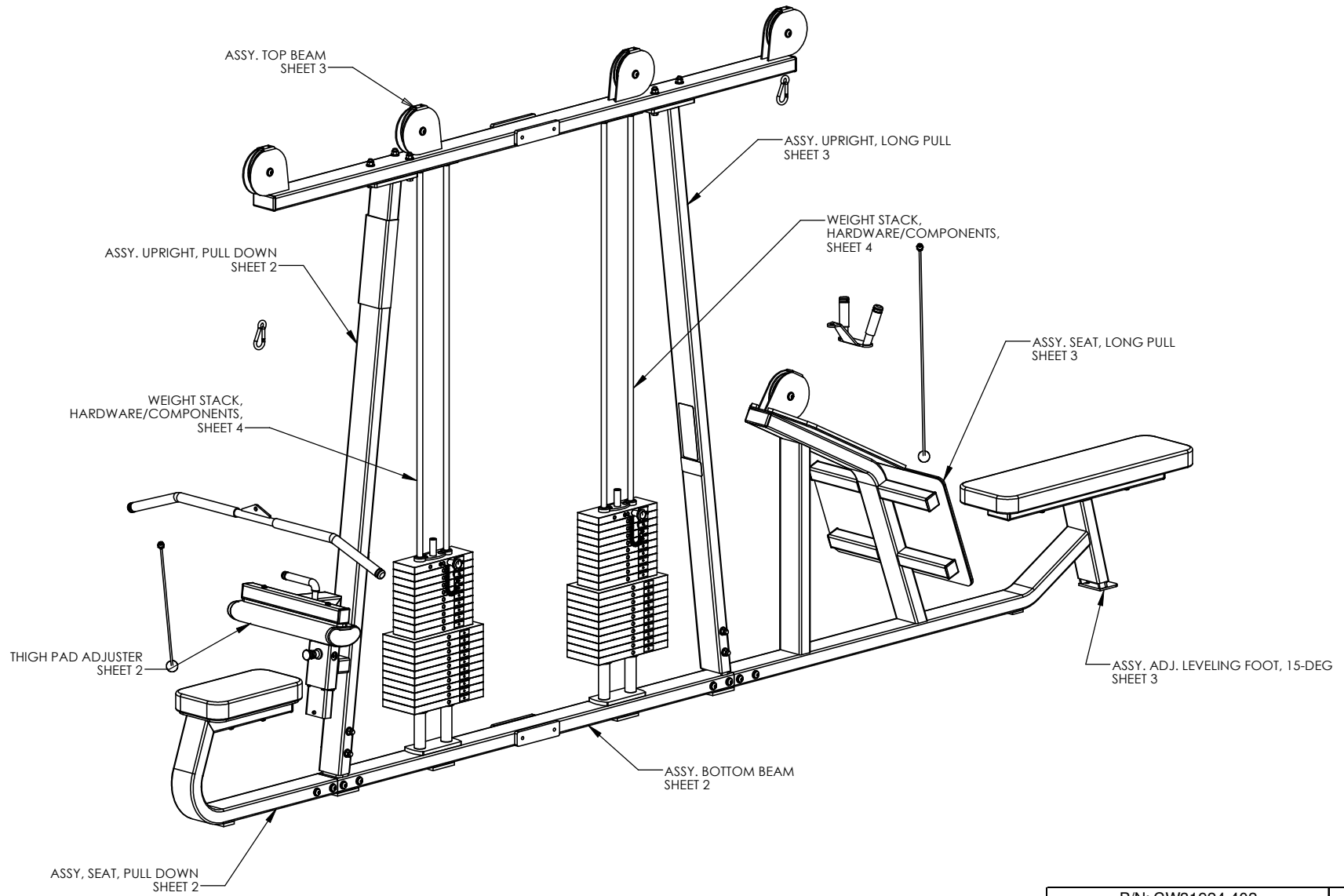

P/N: CW31924-402	SUBREV: E
DRAWN BY: VLE	DATE: 08.18.09
SHEET 1 OF 4	

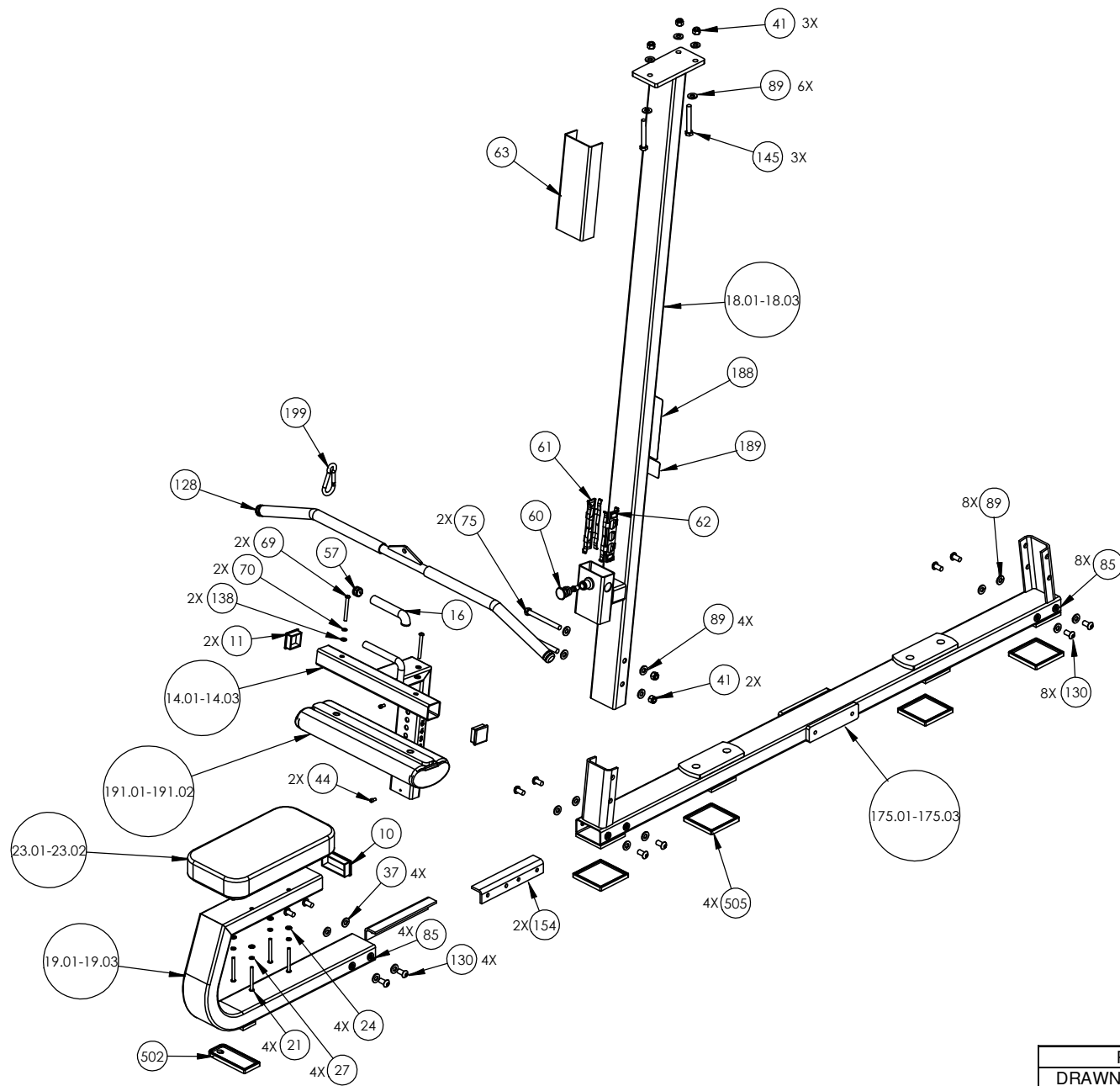

P/N: CW31924-402	SUBREV: E
DRAWN BY: VLE	DATE: 08.18.09
	SHEET 2 OF 4

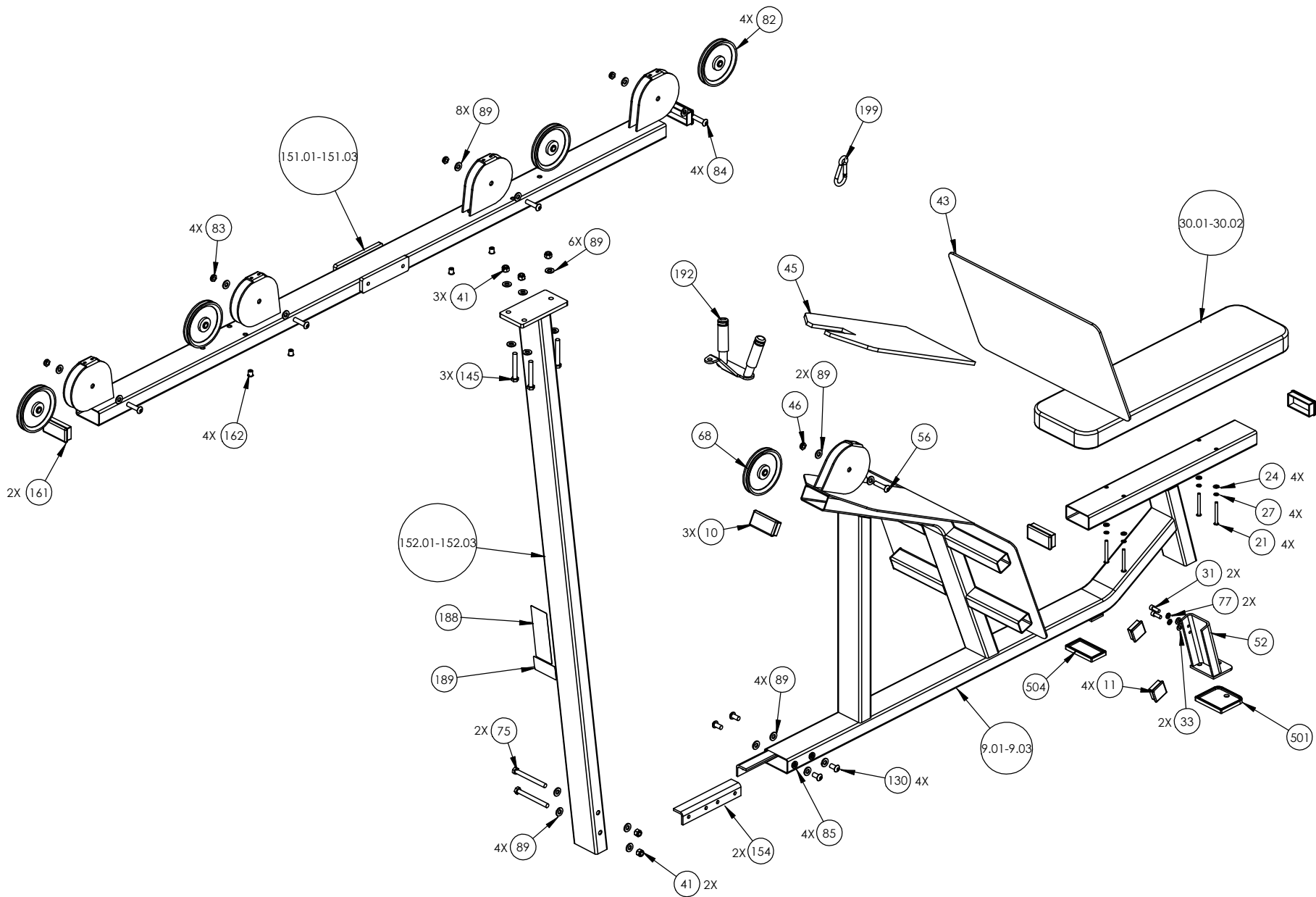

P/N: CW31924-402	SUBREV: E
DRAWN BY: VLE	DATE: 08.18.09
SHEET 3 OF 4	

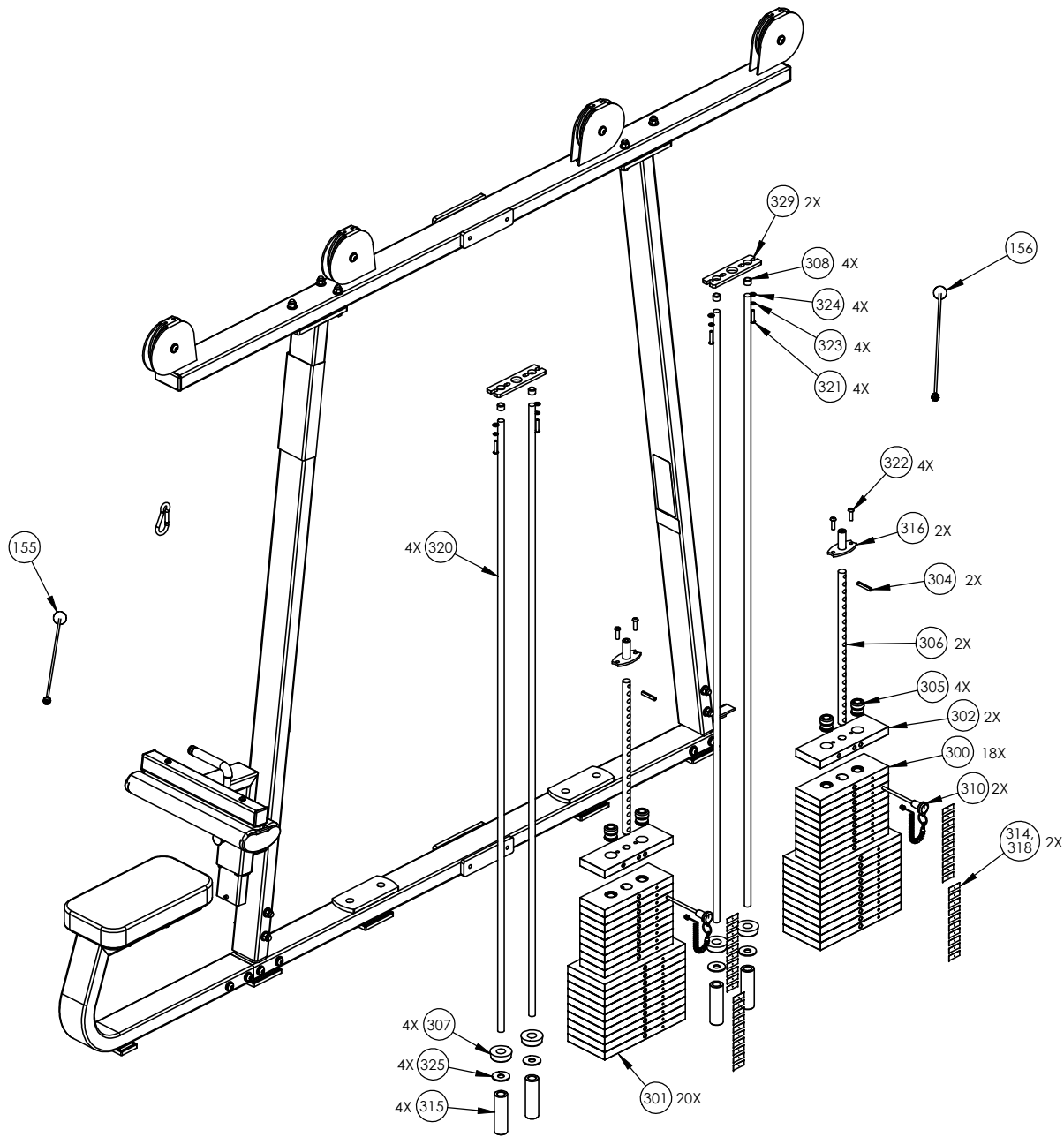

P/N: CW31924-402	SUBREV: E
DRAWN BY: VLE	DATE: 08.18.09
SHEET 4 OF 4	

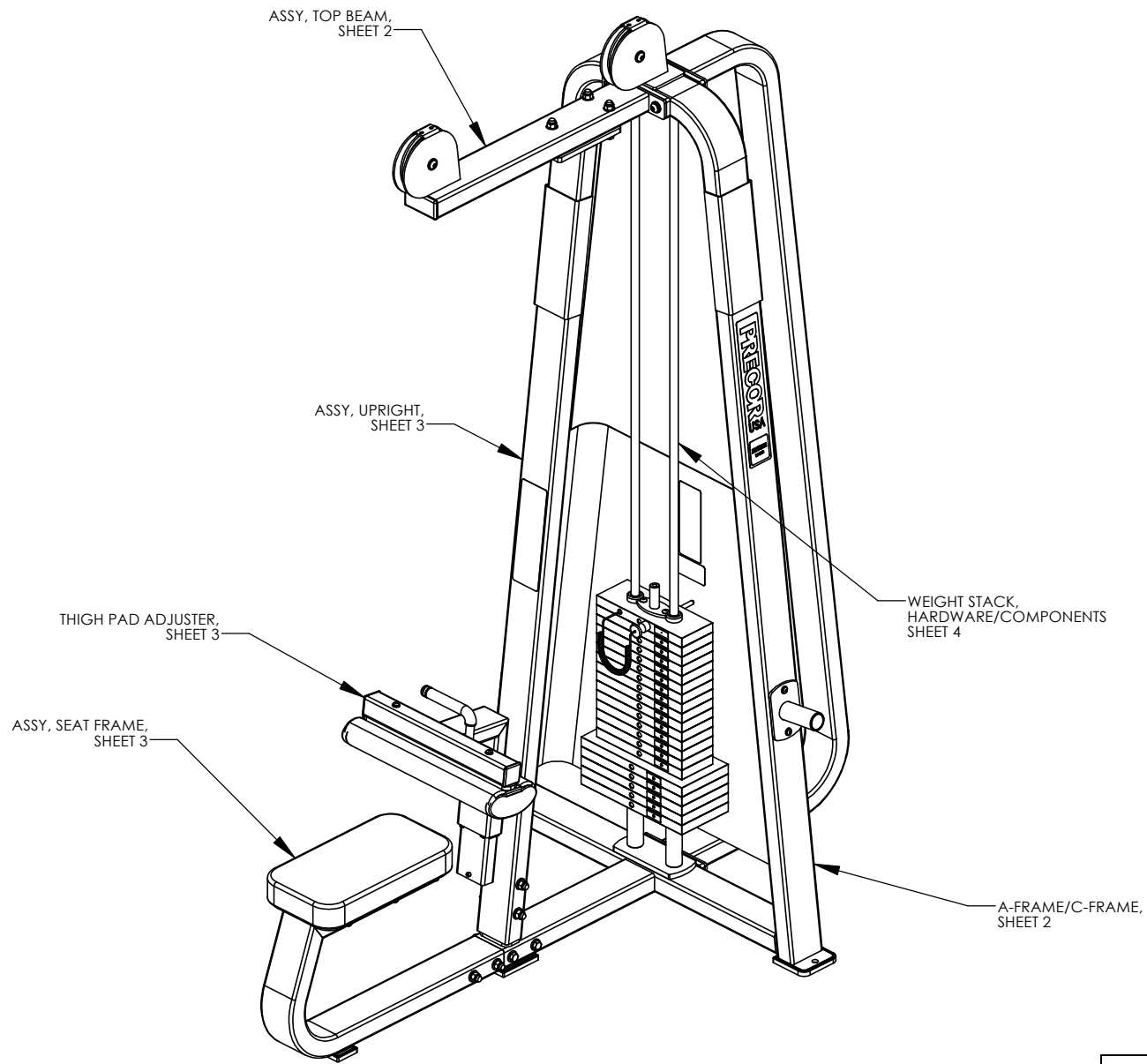

P/N: CW31932-402	SUBREV: C
DRAWN BY: JEC	DATE: 09.11.08
SHEET 1 OF 4	

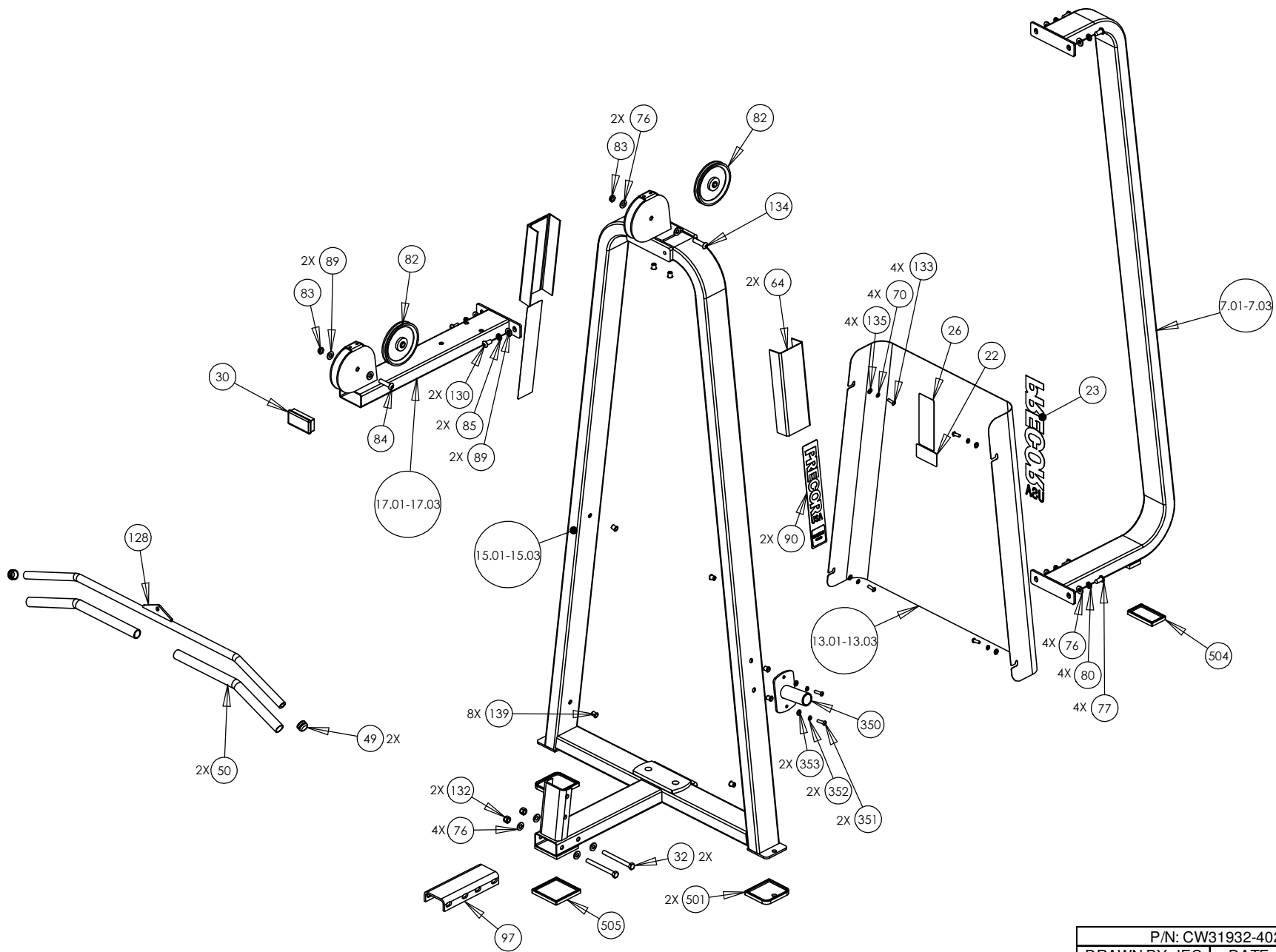

P/N: CW31932-402	SUBREV: C
DRAWN BY: JEC	DATE: 09.11.08
SHEET 2 OF 4	

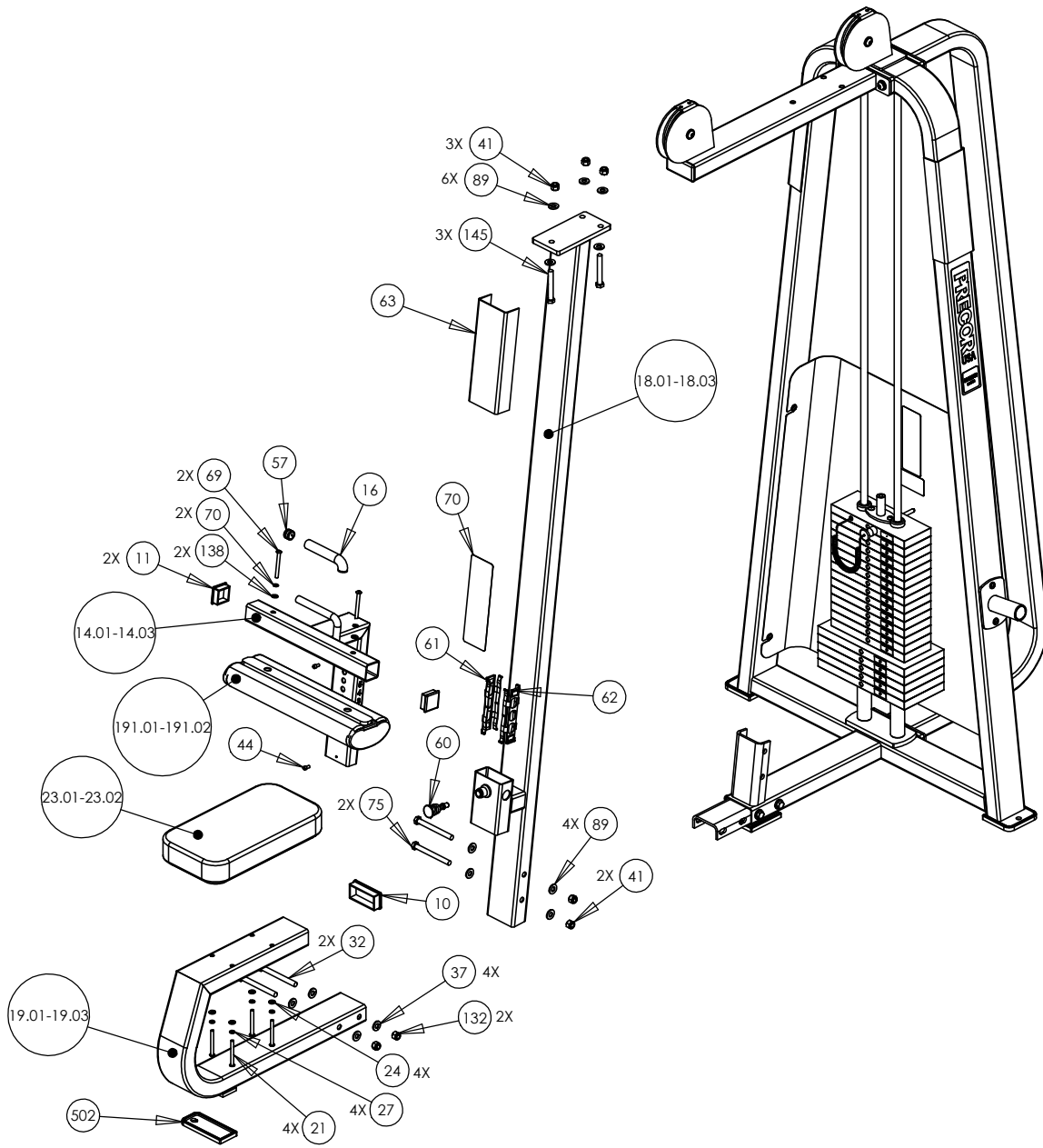

P/N: CW31932-402	SUBREV: C
DRAWN BY: JEC	DATE: 09.11.08
SHEET 3 OF 4	

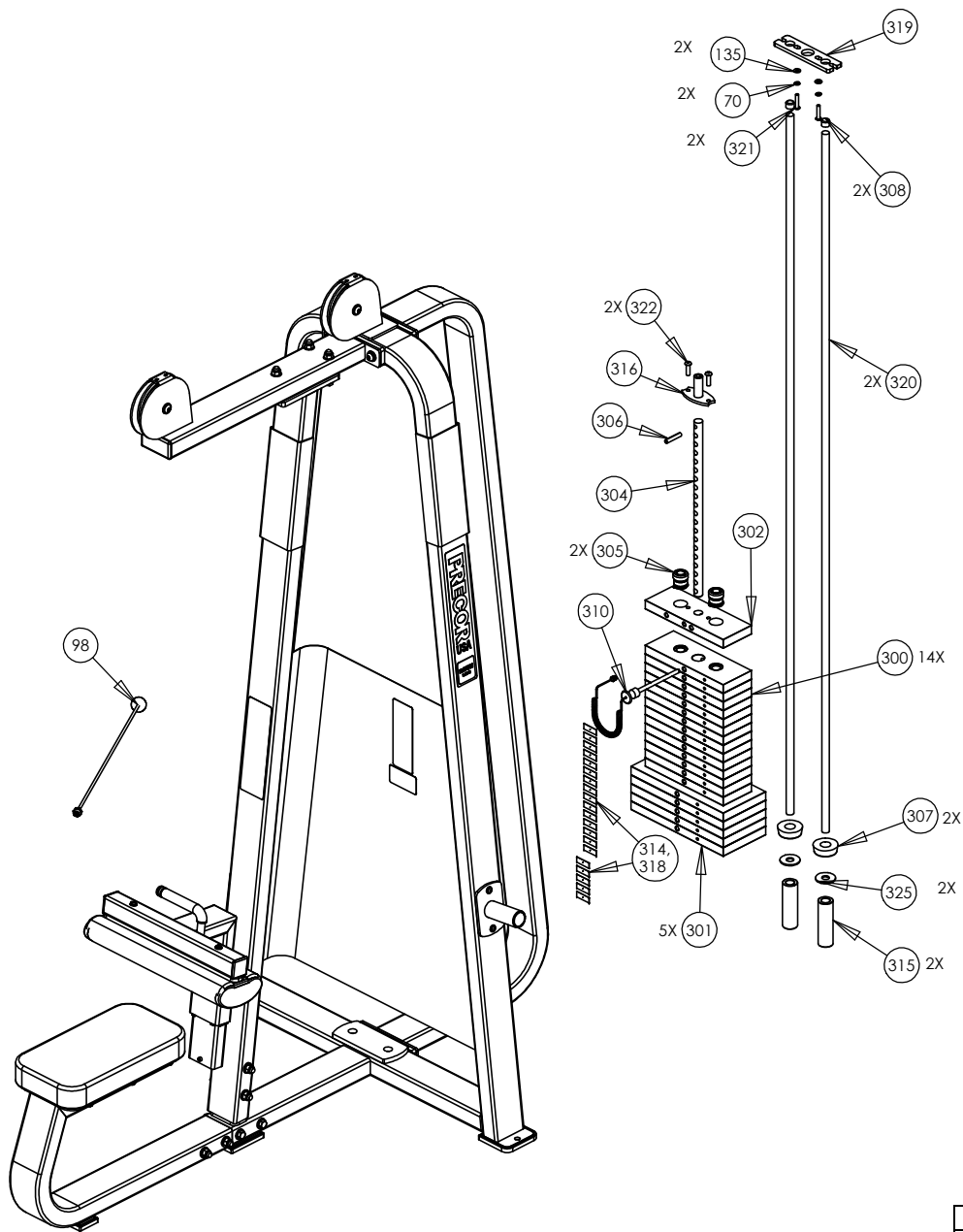

P/N: CW31932-402		SUBREV: C
DRAWN BY: JEC	DATE: 09.11.08	SHEET 4 OF 4

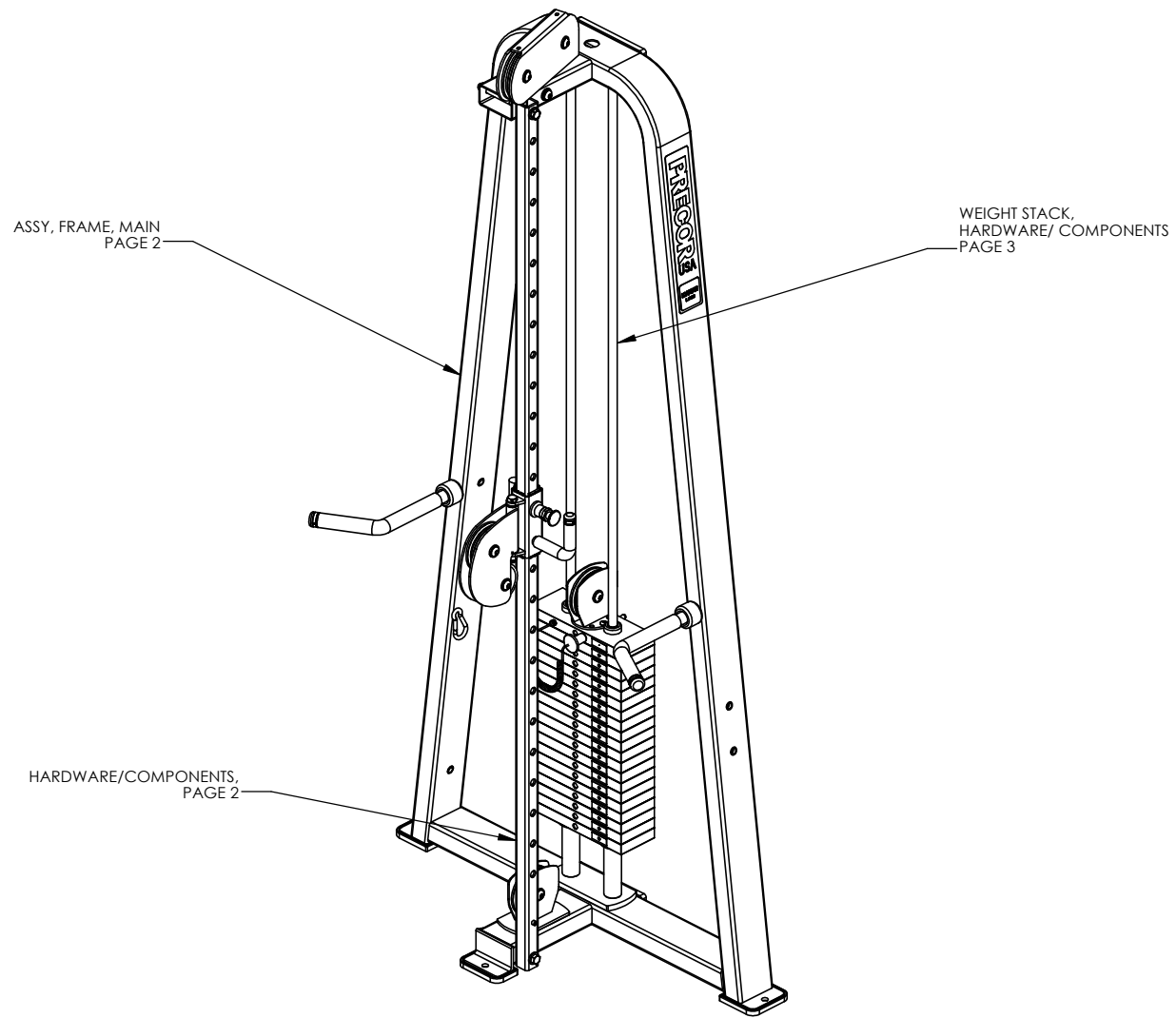

ASSY, FRAME, MAIN
PAGE 2

WEIGHT STACK,
HARDWARE/ COMPONENTS
PAGE 3

HARDWARE/COMPONENTS,
PAGE 2

P/N: CW34920-401		SUBREV: A
DRAWN BY: VLE	DATE: 06.24.09	SHEET 1 OF 3

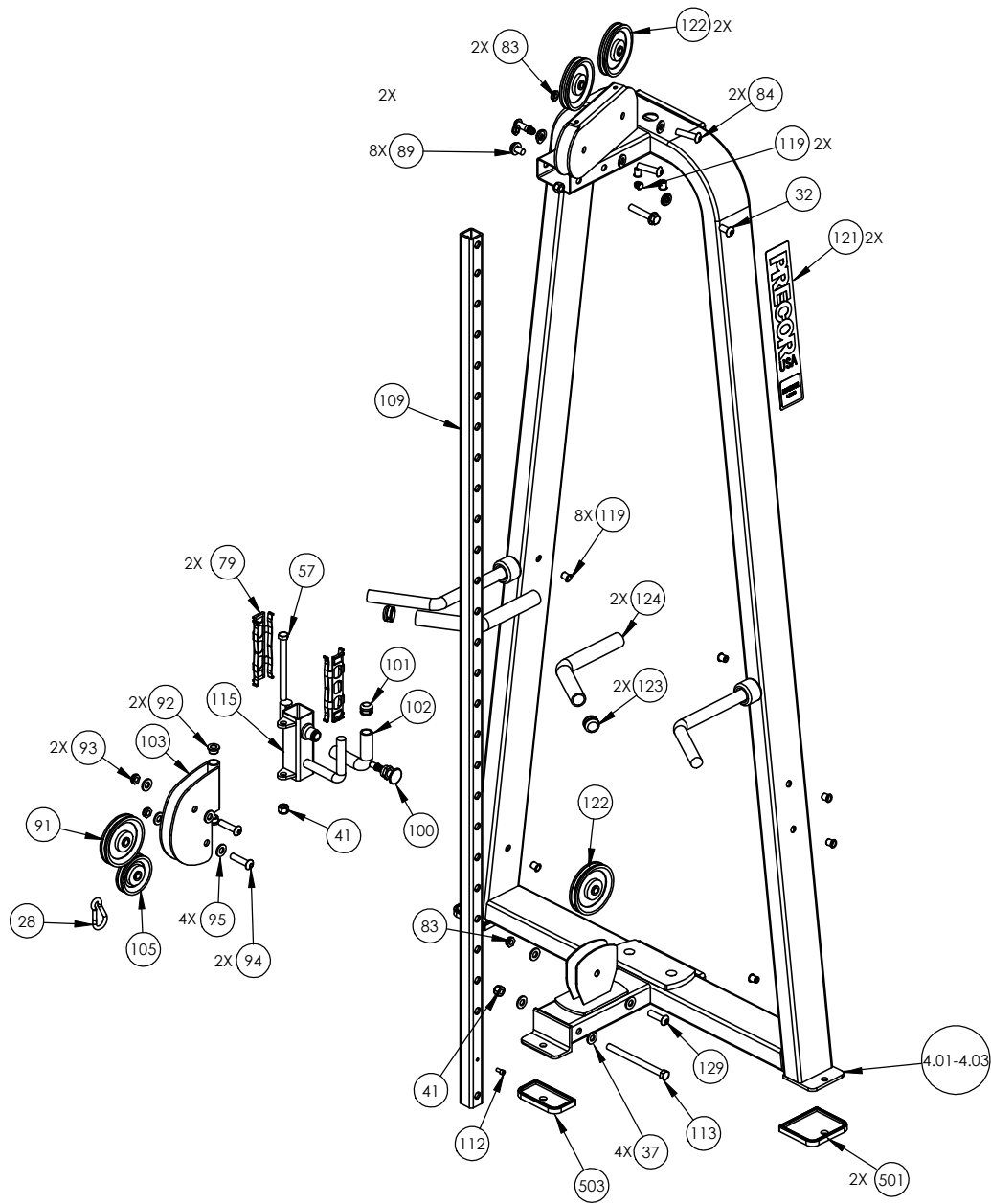

P/N: CW34920-401	SUBREV: A
DRAWN BY: VLE	DATE: 06.24.09
SHEET 2 OF 3	

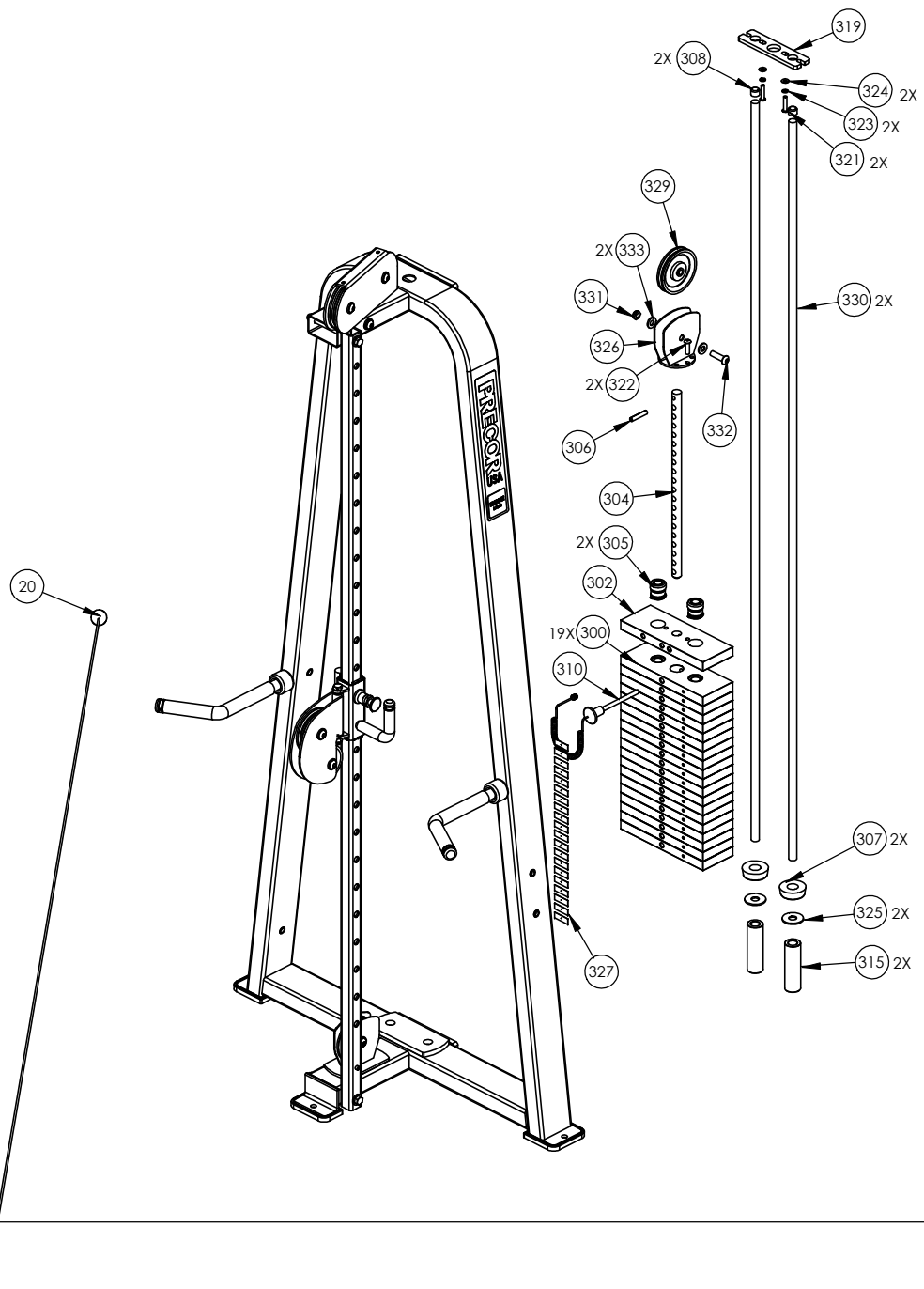

P/N: CW34920-401	SUBREV: A
DRAWN BY: VLE	DATE: 06.24.09
SHEET 3 OF 3	

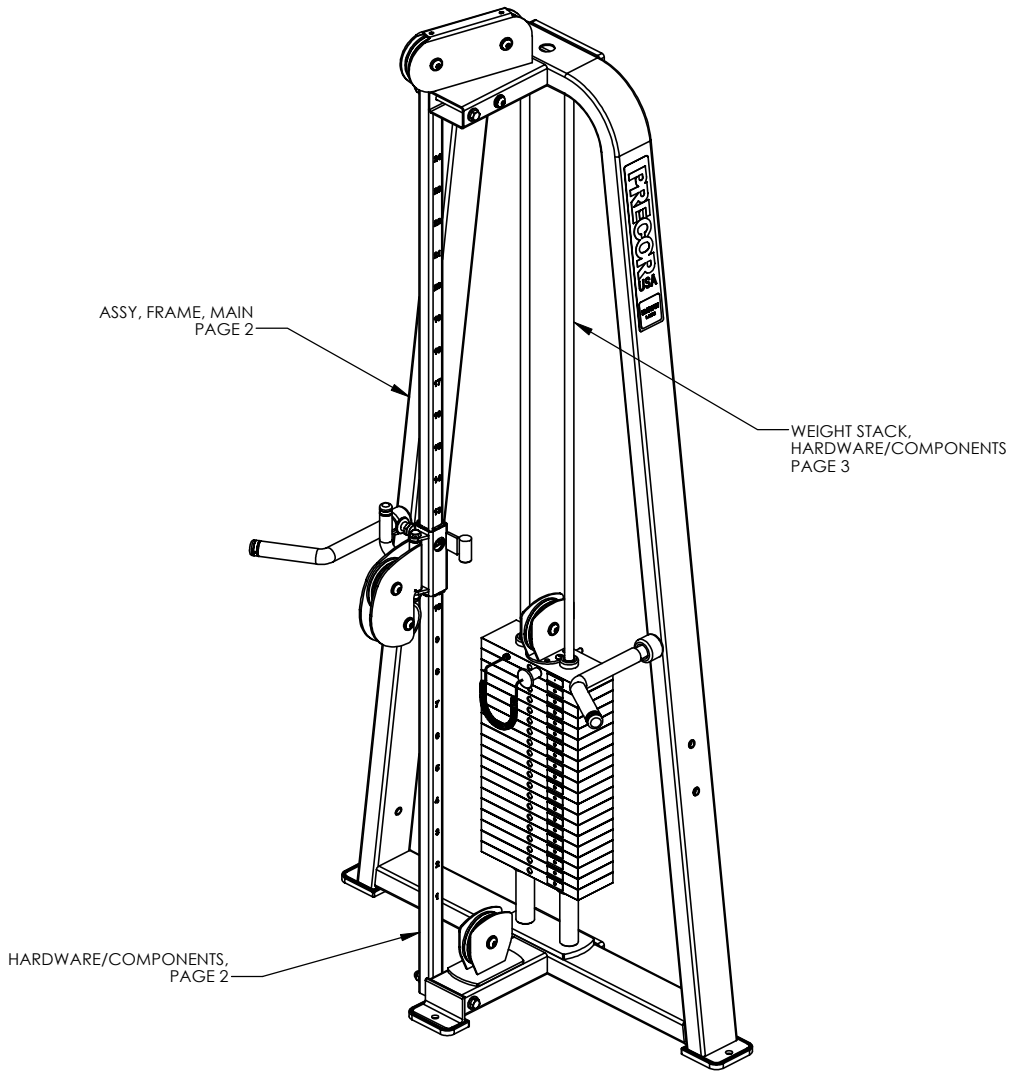

P/N: CW34921-401	SUBREV: A
DRAWN BY: VLE	DATE: 06.24.09
SHEET 1 OF 3	

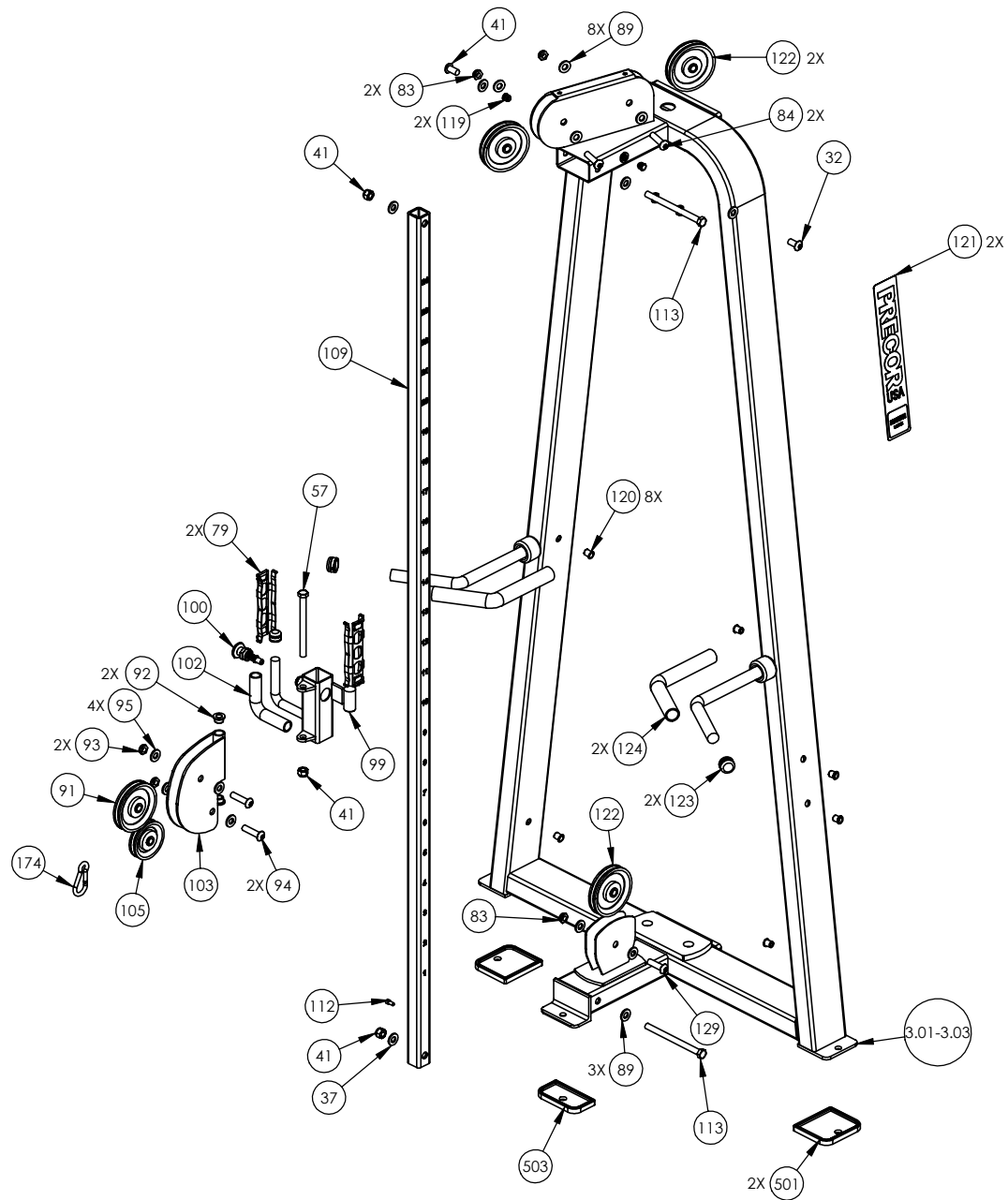

P/N: CW34921-401	SUBREV: A
DRAWN BY: VLE	DATE: 06.24.09
SHEET 2 OF 3	

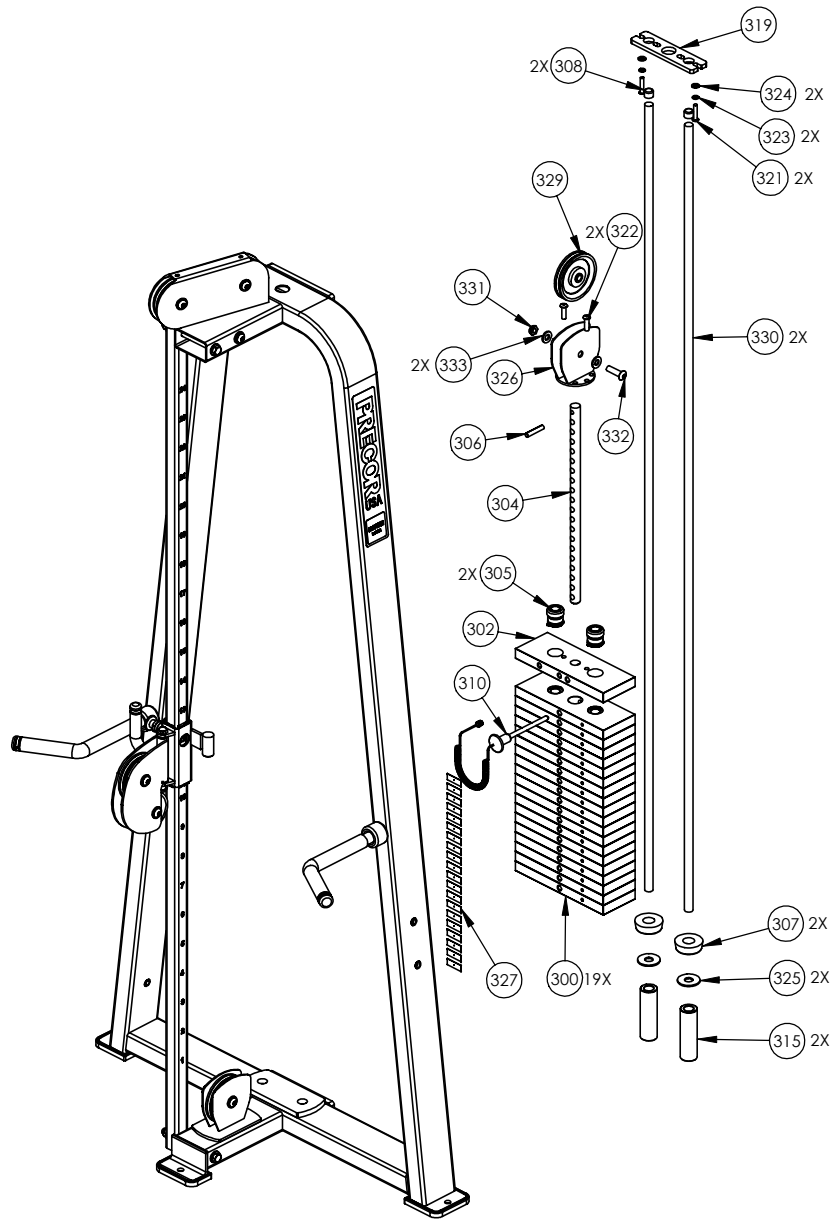

P/N: CW34921-401	SUBREV: A
DRAWN BY: VLE	DATE: 06.24.09
SHEET 3 OF 3	

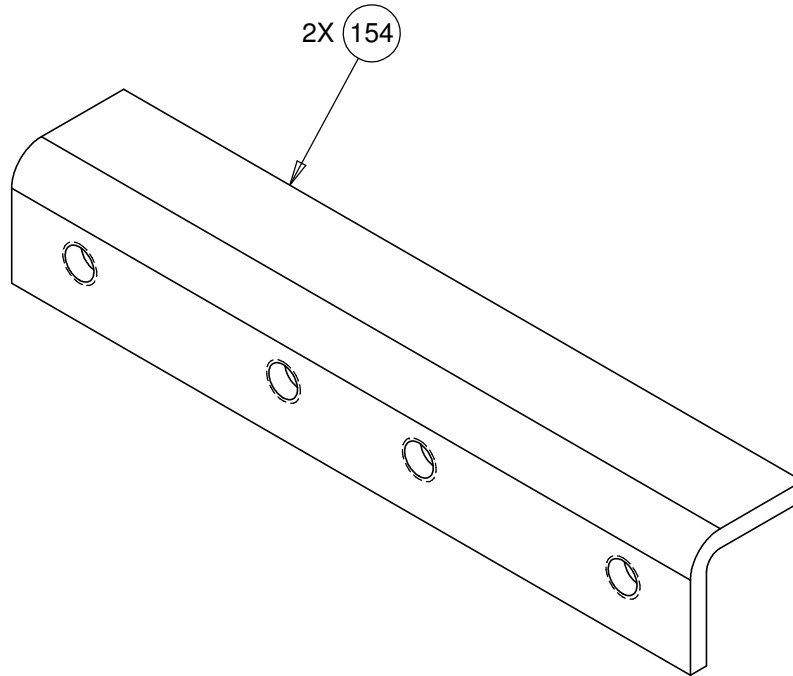

CONFIDENTIAL

THIS DOCUMENT AND INFORMATION CONTAINED HEREIN IS PROPRIETARY AND CONFIDENTIAL TO PRECOR STRENGTH INCORPORATED. RECIPIENTS OF THIS DOCUMENT AGREE THAT THIS DOCUMENT AND INFORMATION WILL NOT BE USED FOR ANY PURPOSE, REPRODUCED OR COPIED, OR DISCLOSED TO ANY THIRD PARTY, EITHER IN WHOLE OR IN PART WITHOUT PRIOR EXPRESS WRITTEN PERMISSION OF PRECOR STRENGTH INCORPORATED.

PRECOR USA
PRECOR STRENGTH, INC.

**28936 AVE WILLIAMS
VALENCIA, CA 91355
TELEPHONE: 661-362-0300**

SIGN IN BLUE OR BLACK INK ONLY			UNLESS OTHERWISE SPECIFIED: DIMENSIONS ARE IN INCHES TOLERANCES ARE:		
DRWN BY	08.27.09	VLE	LIN	.X=±0.1	.XXX=±0.010
DWG CHK			LIN	.XX=±0.02	.XXXX=±0.0001
ENG	08.27.09	VLE	ANGULAR: ±1.0°		
MFG ENG			ALL DIMS AFTER PLATING		
CS			BREAK ALL SHARP EDGES		
QA			REMOVE ALL BURRS		
ID			ALL ANGLES & BENDS 90°		
REG			DWG PER ASME Y14.5M-1994		
			DO NOT SCALE DRAWING		
			125° ALL MACHINED SURFACES		
			SIZE	PAGE	OF
			A	1	1

PRODUCT:
STRENGTH

STEEL, CHANNEL

DWG. NO. **CW33293-402** SUBREV **A**

HANDLES/COMPONENTS
SHEET 3

CARRIAGE/SLIDES,
SHEET 3

WEIGHTS/GUIDE RODS,
SHEET 4

FRAME/C-FRAME,
SHEET 2

CW320KS	P/N: CW33596-101	SUBREV: C
DRAWN BY: JEC	DATE: 09.11.08	SHEET 1 OF 4

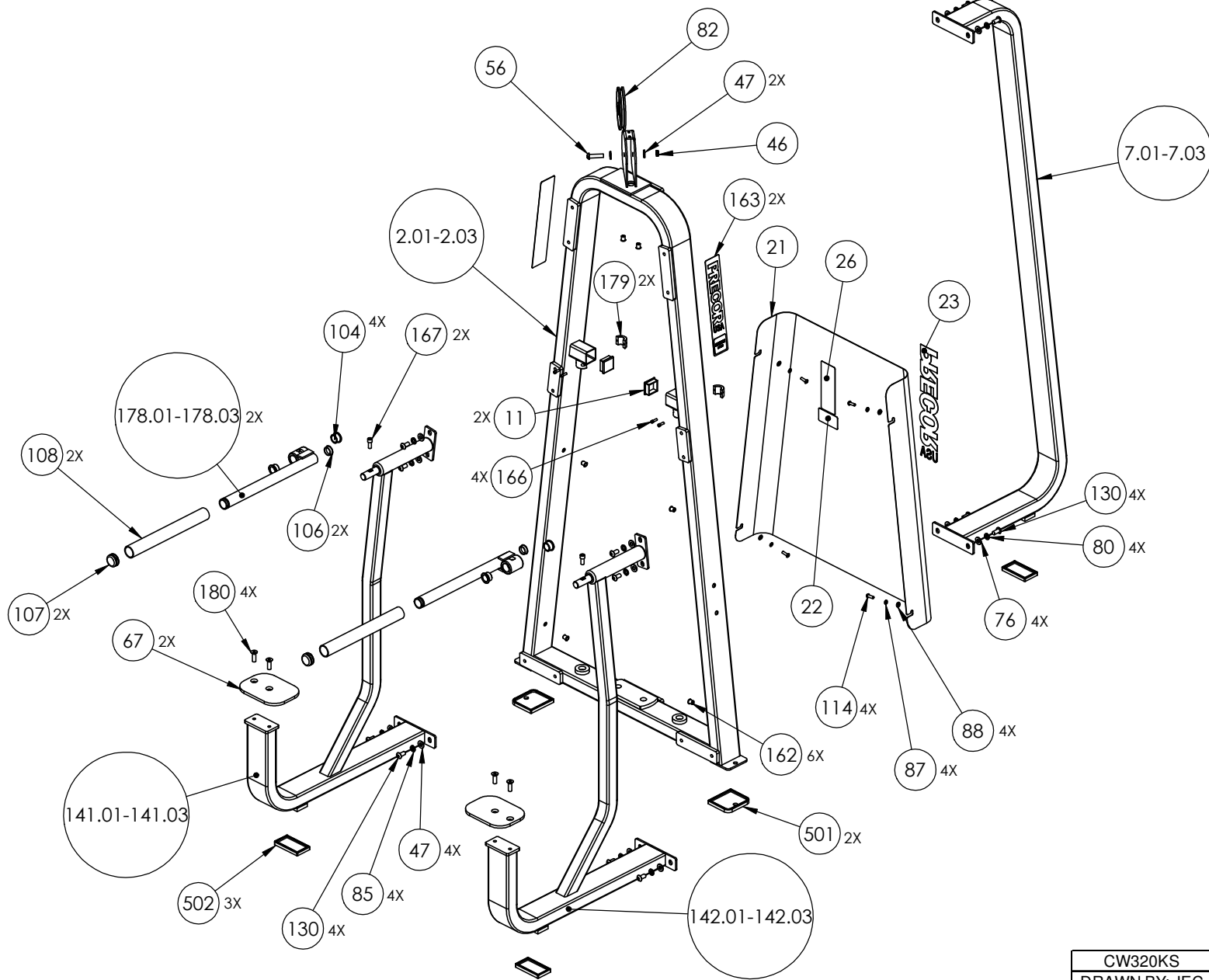

CW320KS	P/N: CW33596-101	SUBREV: C
DRAWN BY: JEC	DATE: 09.11.08	SHEET 2 OF 4

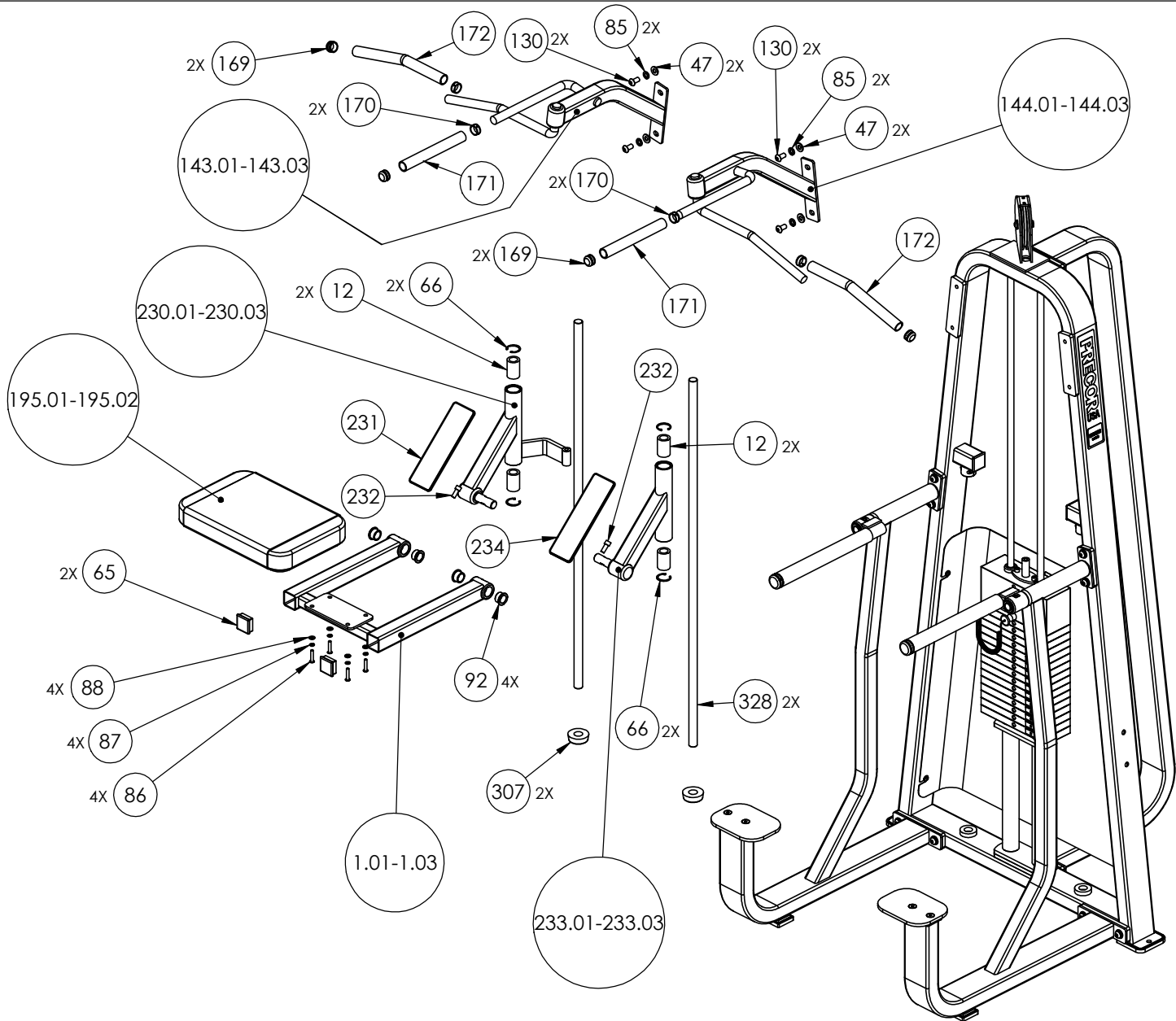

CW320KS	P/N: CW33596-101	SUBREV: C
DRAWN BY: JEC	DATE: 09.11.08	SHEET 3 OF 4

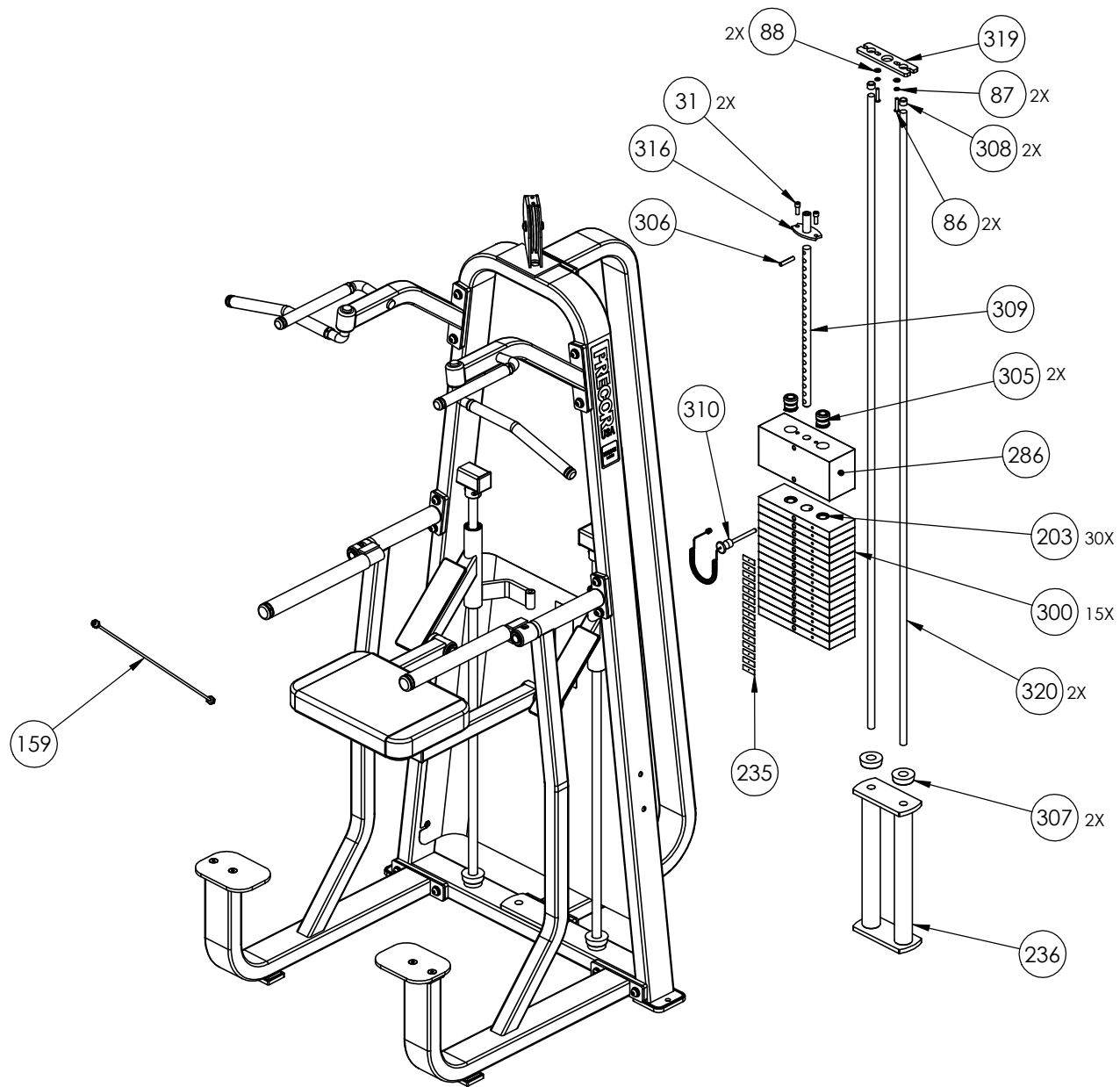

CW320KS	P/N: CW33596-101	SUBREV: C
DRAWN BY: JEC	DATE: 09.11.08	SHEET 4 OF 4

2226 Modular, Dip/Chin Pulldown, Adj. Hi/Low (2X)

Part Number	Description	Bubble Number
PPP00000CW33561212	ASSY, SUPPORT, KNEE PAD, DIP-CHIN A	1.01
PPP00000CW33479213	WELDMENT, FRAME, MAIN, DIP-CHIN ASS	2.01
PPP00000CW11311102	ENDCAP, REC TUBE, 2X4, BLK PLASTIC	10
PPP00000CW11311103	ENDCAP, REC TUBE, 2X2, BLK PLASTIC	11
PPP00000CW12571101	LINEAR BEARING, CLOSED TYPE, 1.000/	12
PPP00000CW30641211	WELDMENT, THIGH PAD ADJUSTER, SKY WH	14.01
PPP00000CW30641301	WELDMENT, THIGH PAD ADJUSTER, CUSTOM	14.02
PPP00000CW30641321	WELDMENT, THIGH PAD ADJUSTER, TITANI	14.03
PPP00000CWGR4804500	GRIP, RUBBER, .75" OD HANDLE, 4.50"	16
PPP00000CW30636211	WELDMENT, TOP BEAM, 304, SKY WHITE	17.01
PPP00000CW30639212	WELDMENT, PULLDOWN UPRIGHT, SKY WHIT	18.01
PPP00000CW30640211	WELDMENT, PULLDOWN SEAT, SKY WHITE	19.01
PPP00000CWCLRA319250	ASSY, CABLE, MARINE EYES, FTS, 407B	20
PPP00000CWAACN125005	RETAINING RING, EXTERNAL 1.250 DIA	23
PPP00000CWPD1105B101	PAD, 9X17, 4HOLES, W/BP, BLACK	23.01
PPP00000CWPD1105B102	PAD, 9X17, 4HOLES, W/BP, RYL BL	23.02
PPP00000CWPD1105B114	PAD, 9X17, 4HOLES, W/BP, CUSTOM	23.14
PPP00000CWWBKN031007	WASHER, FLAT, TYPE A, SAE, 5/16 ID	24
PPP00000CWWALYN050013	WASHER, SPLIT, 1/2 ID, BLK XYLAN	25
PPP00000CWWALYN031008	WASHER, SPLIT, 5/16 ID, BL	27
PPP00000CW12589741	CARBINE, HOOK, MEDIUM, 5/16" DIA, 3	28
PPP00000CW11311102	ENDCAP, REC TUBE, 2X4, BLK PLASTIC	30
PPP00000CWPD1102A101	PAD, FLAT, 10X36, 4HOLES, BLACK	30.01
PPP00000CWPD1102A102	PAD, FLAT, 10X36, 4HOLES, RYL BL	30.02
PPP00000CWPD1102A114	PAD, FLAT, 10X36, 4HOLES, CUSTOM	30.14
PPP00000CWCAYN038100	SCREW, SOCKET HEAD, BLK XYLAN, 3/	31
PPP00000CWWALYN050013	WASHER, SPLIT, 1/2 ID, BLK XYLAN	32
PPP00000CWWBKN038007	WASHER, FLAT, TYPE A, SAE, 3/8 ID	33
PPP00000CWTAYN050100	SCREW, BUTTON HEAD, BLK XYLAN, 1/2	37
PPP00000CWWBKN050010	WASHER, FLAT, TYPE A, SAE, 1/2 ID X	37
PPP00000CWKDYN050059	LOCKNUT, NYLON INSERT, FULL, UNC, 1	41
PPP00000CW30013226	CUT PIECE, CREPE, 1/4 THICK	43
PPP00000CWCAYN025050	SCREW, SOCKET HEAD, BLK XYLAN	44
PPP00000CW30013131	CUT PIECE, CREPE, 1/4 THICK	45
PPP00000CWKAYN050031	LOCKNUT, NYLON INSERT, HALF, UNC, 1	46
PPP00000CWWBKN050010	WASHER, FLAT, TYPE A, SAE, 1/2 ID X	47
PPP00000CWKAYN050031	LOCKNUT, NYLON INSERT, HALF, UNC, 1	48
PPP00000CWWALYN050013	WASHER, SPLIT, 1/2 ID, BLK XYLAN	49
PPP00000CWGR4620000	GRIP, RUBBER, 1.00" OD HANDLE, 20.0	50
PPP00000CWTAYN050200	SCREW, BUTTON HEAD, BLK XYLAN, 1/2	56
PPP00000CWAC220901	HANDLE END CAP W/SET SCREWS, DIA 3/	57
PPP00000CWAC218901	HANDLE END CAP W/SET SCREWS, DIA 1"	58
PPP00000CWAC219902	HNDL RETAINER RNG, W/SS, 1.040" I.D.	59
PPP00000CW30165752	ASSY, POP PIN, 0.450 DIA NOSE, BLU	60
PPP00000CWAC1236104	GUIDE INSERT, PLASTIC WITH HOLE, BL	61
PPP00000CW33508101	ASSY, CUT PIECE, ABS CHANNEL, 1/8 X	63
PPP00000CW33508101	ASSY, CUT PIECE, ABS CHANNEL, 1/8 X	64
PPP00000CW11311103	ENDCAP, REC TUBE, 2X2, BLK PLASTIC	65
PPP00000CWACHN125006	SNAP RING RETAINER, (SUPER 16)	66

PPP0000CW33547781	PLATE, STEEL, FLAT, .25 X 6.00 X 8.	67
PPP0000CWAC1010101	PULLEY, 6 DIA X 1/2 ID	68
PPP000CWWALYN031008	WASHER, SPLIT, 5/16 ID, BL	70
PPP000CWTAYN050200	SCREW, BUTTON HEAD, BLK XYLAN, 1/2	71
PPP000CWWBKN050010	WASHER, FLAT, TYPE A, SAE, 1/2 ID X	72
PPP0000CWGR4605000	GRIP, RUBBER, 1.00" OD HANDLE, 5.00	73
PPP000CWHCCYN050500	SCREW, HEX HEAD, BLK XYLAN, 1/2-13	75
PPP000CWWBKN050010	WASHER, FLAT, TYPE A, SAE, 1/2 ID X	76
PPP000CWWALYN038009	WASHER, SPLIT, 3/8 ID, BLK XYLAN	77
PPP000CWHCCN050600	SCREW, HEX HEAD, ZINC, 1/2-13 X 6	78
PPP00000CW33626901	GUIDE, THIN, TELESCOPING TUBE	79
PPP0000CWAC1010101	PULLEY, 6 DIA X 1/2 ID	82
PPP0000CWKAYN050031	LOCKNUT, NYLON INSERT, HALF, UNC, 1	83
PPP000CWTAYN050200	SCREW, BUTTON HEAD, BLK XYLAN, 1/2	84
PPP000CWWALYN050013	WASHER, SPLIT, 1/2 ID, BLK XYLAN	85
PPP000CWTAYN031150	SCREW, BUTTON HEAD, BLK XYLAN, 5/16	86
PPP000CWWALYN031008	WASHER, SPLIT, 5/16 ID, BL	87
PPP0000CWWBKN031007	WASHER, FLAT, TYPE A, SAE, 5/16 ID	88
PPP000CWWBKN050010	WASHER, FLAT, TYPE A, SAE, 1/2 ID X	89
PPP00000CW31756101	LABEL, PRECOR USA ICARIAN LINE	90
PPP00000CWAC1009101	PULLEY, 4 1/2 DIA X 1/2 ID	91
PPP00000CW10043135	BUSHING, BRONZE, 1 1/4" ID X 1 1/2"	92
PPP00000CW10433108	BUSHING, FLNGD, .75ODX.5IDX.5,IGUS R	92
PPP0000CWKAYN050031	LOCKNUT, NYLON INSERT, HALF, UNC, 1	93
PPP000CWTAYN050200	SCREW, BUTTON HEAD, BLK XYLAN, 1/2	94
PPP000CWWBKN050010	WASHER, FLAT, TYPE A, SAE, 1/2 ID X	95
PPP00000CWAC218901	HANDLE END CAP W/SET SCREWS, DIA 1"	96
PPP00000CW33293733	STEEL, ANGLE, HR, [3.15 X .25 X 1.6	97
PPP000CWCCLGY101125	ASSY, CABLE, MARINE EYES, 304SM	98
PPP00000CW30165752	ASSY, POP PIN, 0.450 DIA NOSE, BLU	100
PPP00000CWAC220901	HANDLE END CAP W/SET SCREWS, DIA 3/	101
PPP00000CWGR4806000	GRIP, RUBBER, .75" OD HANDLE, 6.00"	102
PPP00000CW30497721	WELDMENT, W/2 PULLEY WHEELS, WRKL B	103
PPP00000CW10043134	BUSHING, BRONZE, 1" ID X 1 1/4" OD	104
PPP00000CWAC1008101	PULLEY, 3 1/2 DIA. X 1/2 ID	105
PPP00000CW11095105	CAP, PLASTIC, HEYCO, DOME PLUG, 1.2	106
PPP00000CWAC242901	HANDLE END CAP W/SET SCREWS, DIA 1	107
PPP00000CWGR4915000	GRIP, RUBBER, 1.50" OD HANDLE, 15.0	108
PPP00000CWPF4020713	TUBE, STEEL, HRPO, 1 1/2 X 1 1/2 X 3/	109
PPP00000CWCAYN025050	SCREW, SOCKET HEAD, BLK XYLAN	112
PPP00000CWHCCN050600	SCREW, HEX HEAD, ZINC, 1/2-13 X 6	113
PPP00000CW35150101	ASSY, D- HANDLE	114
PPP00000CWTAYN031100	SCREW, BUTTON HEAD, BLK XYLAN, 5/16	114
PPP00000CWEANN050075	SCREW, SET, SCKT, CUP POINT, 1/2-13	117
PPP00000CW11311102	ENDCAP, REC TUBE, 2X4, BLK PLASTIC	118
PPP00000CW11382105	CAP, TUBE, PLASTIC, ROUND, CCF-5/8-	119
PPP00000CW12537109	NUT, INSERT, THIN-NUT, LARGE FLANGE	120
PPP00000CW31756101	LABEL, PRECOR USA ICARIAN LINE	121
PPP00000CWAC1009101	PULLEY, 4 1/2 DIA X 1/2 ID	122
PPP00000CWAC218901	HANDLE END CAP W/SET SCREWS, DIA 1"	123
PPP00000CWAC4003101	ACCESSORY, PRO STYLE BAR, SOLID, 32	125

PPP0000CWAC4011101	ACCESSORY, HANDLE , NYLON ROPE W/BA	126
PPP0000CWAC4013101	ACCESSORY, LAT BAR , SOLID, 48"	127
PPP0000CWSA1081731	ASSY,LAT BAR,BLK ZNC	128
PPP0000CWTAYN050100	SCREW, BUTTON HEAD, BLK XYLAN, 1/2	130
PPP0000CWHCYN050275	SCREW, HEX HEAD, BLK XYLAN, 1/2-13	131
PPP0000CWTAYN031100	SCREW, BUTTON HEAD, BLK XYLAN, 5/16	133
PPP0000CWTAYN050200	SCREW, BUTTON HEAD, BLK XYLAN, 1/2	134
PPP0000CWWBKN031007	WASHER, FLAT, TYPE A, SAE, 5/16 ID	135
PPP0000CWWBKN031007	WASHER, FLAT, TYPE A, SAE, 5/16 ID	138
PPP000000CW12537109	NUT,INSERT,THIN-NUT,LARGE FLANGE	139
PPP000000CW33552211	ASSY, ARM, LEFT, DIP-CHIN ASSIST, 3	143.01
PPP000000CW33556211	ASSY, ARM, RIGHT, DIP-CHIN ASSIST,	144.01
PPP0000CWHCYN050350	SCREW, HEX HEAD, BLK XYLAN, 1/2-13	145
PPP000000CW30643302	WELDMENT, LINK BRACKET, CUSTOM	149.02
PPP000000CW30643322	WELDMENT, LINK BRACKET, TITANIUM, H	149.03
PPP000000CW31887212	WELDMENT, TOP BEAM, SKY WHITE	151.01
PPP000000CW31887302	WELDMENT, TOP BEAM, CUSTOM	151.02
PPP000000CW31887322	WELDMENT, TOP BEAM, TITANIUM	151.03
PPP000000CW31891211	WELDMENT, UPRIGHT, LONG PULL, SKY W	152.01
PPP000000CW31891301	WELDMENT, UPRIGHT, LONG PULL, CUSTO	152.02
PPP000000CW31891321	WELDMENT, UPRIGHT, LONG PULL, TITAN	152.03
PPP000000CW33293733	STEEL, ANGLE, HR, [3.15 X .25 X 1.6	154
PPP0000CWCLGY101125	ASSY, CABLE, MARINE EYES, 304SM	155
PPP0000CWCLGY155750	ASSY, CABLE, MARINE EYES, 302M	156
PPP0000CWCLGG098500	ASSY, CABLE, 320	160
PPP000000CW11311102	ENDCAP, REC TUBE, 2X4, BLK PLASTIC	161
PPP000000CW12537109	NUT,INSERT,THIN-NUT,LARGE FLANGE	162
PPP000000CW31756101	LABEL, PRECOR USA ICARIAN LINE	163
PPP0000CWCGYN025075	SCREW, SOCKET HEAD, BLK XYLAN, 1/4-	166
PPP0000CWCAYN044100	SCREW, SOCKET HEAD, BLK XYLAN, 7/1	167
PPP000000CWAC218901	HANDLE END CAP W/SET SCREWS, DIA 1"	169
PPP000000CWAC219902	HNDL RETAINER RNG, W/SS,1.040" I.D.	170
PPP000000CWGR4610000	GRIP, RUBBER, 1.00" OD HANDLE, 10.0	171
PPP000000CWGR4615000	GRIP, RUBBER, 1.00" OD HANDLE, 15.0	172
PPP0000CWCLRA319250	ASSY, CABLE, MARINE EYES, FTS,407B	173
PPP000000CW12589741	CARBINE, HOOK, MEDIUM, 5/16" DIA, 3	174
PPP000000CW33302211	WELDMENT, BOTTOM BEAM, SKY WHITE	175.01
PPP000000CW33302301	WELDMENT, BOTTOM BEAM, CUSTOM	175.02
PPP000000CW33302321	WELDMENT, BOTTOM BEAM, TITANIUM, HG	175.03
PPP000000CW30491211	WELDMENT, PIVOTING, HANDLE, PT, SKY	178.01
PPP000000CW30491301	WELDMENT, PIVOTING, HANDLE, PT, CUS	178.02
PPP000000CW30491321	WELDMENT, PIVOTING, HANDLE, PT	178.03
PPP000000CW33668732	SHAFT COLLAR, 1.00 ID X 1.75 OD, W/	179
PPP0000CWMAJGN050150	SCREW, FLAT HEAD, SOCKET,BLK OXIDE,	180
PPP000000CW30010102	LABEL,WARNING STRENGTH	188
PPP000000CW30011102	LABEL,WARNING WEIGHT STACK	189
PPP0000CWPD1141J101	PAD,4X19,2HOLES,W/BP,BLACK, W/SLIP	191.01
PPP0000CWPD1141J102	PAD,4X19,2HOLES,W/BP,RYL BL, W/SLIP	191.02
PPP0000CWPD1141J114	PAD,4X19,2HOLES,W/BP,CUSTOM,W/SLIP	191.14
PPP000000CW31595731	HANDLE, NARROW GRIP ROW, BLACK ZINC	192
PPP000000CW31597731	HANDLE, WIDE GRIP ROW, BLACK ZINC	193

PPP0000CWAC4020101	ACCESSORY, HANDLE , DOUBLE D, SOLID	194
PPP0000CWPD1137J101	PAD,12X18,4HOLES,W/BP,BLACK,W/SLIP	195.01
PPP0000CWPD1137J102	PAD,12X18,4HOLES,W/BP,RYL BL,W/SLIP	195.02
PPP0000CWPD1137J114	PAD,12X18,4HOLES,W/BP,CUSTOM,W/SLIP	195.14
PPP00000CW12589742	CARBINE, HOOK, LARGE, 3/8" DIA, 3 1	199
PPP0000CWAC1133101	BUSHING, WEIGHT PLATE, LDPE PLASTIC	203
PPP00000CW33565212	ASSY, SLIDE, LEFT, DIP-CHIN ASSIST,	230.01
PPP00000CW33571101	ASSY, PLACARD, LEFT, 320KS	231
PPP0000CWCAKN063100	SCREW, SOCKET HEAD, BLK ZN, 5/8-11	232
PPP00000CW33569212	ASSY, SLIDE, RIGHT, DIP-CHIN ASSIST	233.01
PPP00000CW33572101	ASSY, PLACARD, RIGHT, 320KS	234
PPP00000CW32934101	WEIGHT STACK LABELS, 10-150, STRAIG	235
PPP00000CW33557721	WELDMENT, WEIGHT STACK RISER, WRKL	236
PPP00000CW10519721	PLATE, WEIGHT, 20 LBS, WRKL BLK	279
PPP00000CW10510721	ASSY, PLATE, WEIGHT, 10 LBS, WRKL B	300
PPP00000CW10520721	ASSY, PLATE, WEIGHT, 20 LBS, WRKL B	301
PPP00000CW30132712	SELECTOR STEM, 20 PLATE,0.875 DIA,	304
PPP00000CW30184902	ASSY,BARREL,TOP PLATE,ALUMINUM	305
PPP0000CWLDNN038200	SLOTTED PIN SPRING, DIA 3/8 X 2	306
PPP00000CW12402101	BUMPER, ID 1.050, BLK RUBBER	307
PPP00000CW12404101	CAP, GUIDE ROD,DIA 3/4, BLK	308
PPP00000CW33870102	ASSEMBLY, 5" WEIGHT STACK PIN & LEA	310
PPP00000CW32937101	WEIGHT STACK LABELS, 10-250, STAGGE	314
PPP00000CW33323721	STACK RISER, 5 INCH, WRINKLE BLACK	315
PPP00000CW32663741	WELDMENT, BOLT ON TOP PLATE MINI ST	316
PPP00000CW32938101	WEIGHT STACK LABELS, 10-300, STAGGE	318
PPP00000CWPF1016101	UHMWPE, GUIDE ROD CAPTURE PLATE	319
PPP00000CWPF1218712	GUIDE ROD,DIA 3/4, #8,CHM	320
PPP0000CWTAYN031175	SCREW, BUTTON HEAD, BLK XYLAN, 5/16	321
PPP0000CWTAYN038125	SCREW, BUTTON HEAD, BLK XYLAN, 3/8	322
PPP0000CWWALYN031008	WASHER, SPLIT, 5/16 ID, BL	323
PPP0000CWWBKN031007	WASHER, FLAT, TYPE A, SAE, 5/16 ID	324
PPP0000CWWCKN075015	WASHER, FLAT, TYPE A, WIDE, 3/4 ID	325
PPP00000CW32651721	WELDMENT, 4.50" TOP PLATE PULLEY HO	326
PPP00000CWPF3503901	GUIDE ROD,STEEL,OD .995 X 50.38, CA	328
PPP00000CWAC1009101	PULLEY, 4 1/2 DIA X 1/2 ID	329
PPP00000CWKAYN050031	LOCKNUT, NYLON INSERT, HALF, UNC, 1	331
PPP0000CWTAYN050175	SCREW, BUTTON HEAD, BLK XYLAN, 1/2	332
PPP0000CWWBKN050010	WASHER, FLAT, TYPE A, SAE, 1/2 ID X	333
PPP00000CWAC1177101	FLOOR PROTECTOR, RUBBER, 4.563 X 4.	501
PPP00000CWAC1178101	FLOOR PROTECTOR, RUBBER, 2.563 X 6.	502
PPP00000CWAC1179101	FLOOR PROTECTOR, RUBBER, 4.813 X 2.	503
PPP00000CWAC1180101	FLOOR PROTECTOR, RUBBER, 2.563 X 4.	504
PPP00000CWAC1181101	FLOOR PROTECTOR, RUBBER, 4.563 X 4.	505
PPP00000CW58004101	WEIGHT STACK BUSHING KIT, KS SERIES	600